



6450-C

FROZEN BEVERAGE FREEZER

Single flavor, Countertop, Gravity feed

Most **Compact & Versatile**

Single flavor counter model for frozen beverage, smoothies and milkshakes

Fast Freeze Down

Patented high efficiency heat exchanger allows fast freeze down with low energy consumption

Simple Control, Easy Operation

Simple and intuitive control system makes operation and viscosity adjustment easy, swift and more precise

Low Mix Indicator

Light turns "ON" at low mix to alert operator to add mix

See-through Dispensing Door

Clear dispensing door design makes product more attractive and serves as great marketing tool

Standby & Indicator

Maintains product temperature in both mix hopper and freezing cylinder below 4.4°C (40°F) overnight; Indicator lights up during Standby

Higher capacity solution with greater flexibility to serve larger crowds alcoholic & non-alcoholic frozen drinks including milkshakes



Hopper Agitators

Maintain product consistency and prevent product separation

Self-closing Dispensing Valve

Automatically prevents product overflow after dispense

Safety Protections

- High pressure switch to prevent compressor overheating
- Thermal overload to protect from motor overheating

Light Box (Optional)

- Illuminates advertising cards to attract more business
- Changes color to indicate Low Mix and Standby

One-hand Operated Spinner (Optional)

- Adds ability to blend and offer more varieties of treats
- Allows for multi-tasking one-hand operation that helps increase productivity and reduce serving time



6450-C

FROZEN BEVERAGE FREEZER

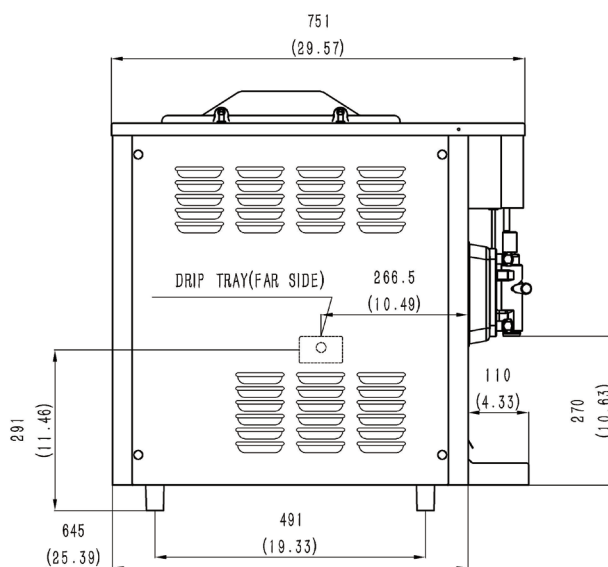
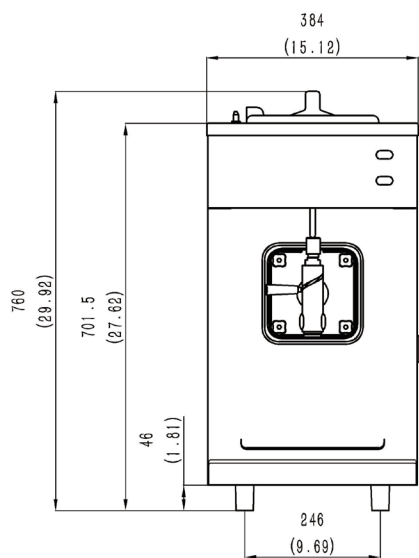

SPECIFICATIONS

Flavors	1
Freezing Cylinders	1x 3.8L / 4.0qt
Mix Hoppers	1x 12L / 12.7qt
Output Capacity (250ml)	80 serves/hr
Clearance Requirements	152mm/6" on back

Weight Kg/lb

Net	99 / 218
Shipping	109 / 240
Volume	0.30 CBM / 10.43 CBF

Dimensions Net (mm/in) Shipping (mm/in)

Width	384 / 15.1	420 / 16.5
Depth	645 / 25.4	790 / 31.1
Height	760 / 29.9	890 / 35.0

Electrical Power (kW) Total Amps (A) Fuse (A)

220-240/50/1	1.6	7	13
208-230/60/1	1.6	8	15
110-120/60/1	1.4	14	20

• Above specifications are subject to change without notice

FEATURES

Control System	One, Mechanical
Refrigerated Hopper	<input checked="" type="checkbox"/>
Hopper Agitator	<input checked="" type="checkbox"/>
Auto Closing Dispensing Valve	<input checked="" type="checkbox"/>
Low Mix Indicator Light	<input checked="" type="checkbox"/>
Low Mix Indicator Alarm	<input checked="" type="checkbox"/>
Standby Mode	<input checked="" type="checkbox"/>
Standby Indicator Light	<input checked="" type="checkbox"/>
High Pressure Protection	<input checked="" type="checkbox"/>
Thermal Overload Protection	<input checked="" type="checkbox"/>

AVAILABLE OPTIONS

Top Air Discharge Chute	<input checked="" type="checkbox"/>
Spinner	<input checked="" type="checkbox"/>
Light Box	<input checked="" type="checkbox"/>